

DOCUMENT RESUME

ED 179 393

SE 029 297

AUTHOR Hamilton, Howard B.
 TITLE Laboratory Manual for Power Processing, Part 1. Electric Machinery Analysis.
 INSTITUTION Pittsburgh Univ., Pa.
 SPONS AGENCY National Science Foundation, Washington, D.C.
 PUB DATE 70
 GRANT NSF-GY-4138
 NOTE 45p.; For related documents, see SE 029 295-298; Page 16a removed due to oversize

EDRS PRICE MF01/PC02 Plus Postage.
 DESCRIPTORS *College Science: Curriculum Development; Electricity: Electromechanical Technology; Electronics: *Engineering Education; Higher Education: *Laboratory Procedures; *Science Courses; Science Curriculum; Science Education; *Science Experiments: Science Materials

ABSTRACT

This publication was developed as a portion of a two-semester sequence commencing at either the sixth or seventh term of the undergraduate program in electrical engineering at the University of Pittsburgh. The materials of the two courses, produced by a National Science Foundation grant, are concerned with power conversion systems comprising power electronic devices, electromechanical energy converters, and associated logic configurations necessary to cause the system to behave in a prescribed fashion. The emphasis in this portion of the two sequences (Part 1) is on electric machinery analysis. This publication is the laboratory manual for Part 1, which presents eleven experiments. These experiments deal with transformers, direct current machines, cross field machines, synchronous machines, asynchronous machines, and the speed-torque curve of an induction motor. (HM)

 * Reproductions supplied by EDRS are the best that can be made *
 * from the original document. *

ED179393

LABORATORY MANUAL
for
POWER PROCESSING, PART I
"Electric Machinery Analysis"

U.S. DEPARTMENT OF HEALTH,
EDUCATION & WELFARE
NATIONAL INSTITUTE OF
EDUCATION

THIS DOCUMENT HAS BEEN REPRODUCED EXACTLY AS RECEIVED FROM THE PERSON OR ORGANIZATION ORIGINATING IT. POINTS OF VIEW OR OPINIONS STATED DO NOT NECESSARILY REPRESENT OFFICIAL NATIONAL INSTITUTE OF EDUCATION POSITION OR POLICY.

"PERMISSION TO REPRODUCE THIS MATERIAL HAS BEEN GRANTED BY

Mary L. Charles
NSF

TO THE EDUCATIONAL RESOURCES INFORMATION CENTER (ERIC)."

Howard B. Hamilton

University of Pittsburgh

1970

SE 029 297



The preparation of this material has been partially supported by Grant GY-4138 entitled "Course Content Improvement Project for Power Processing" made to the University of Pittsburgh by the National Science Foundation.

Copyright, 1970 by Howard B. Hamilton

General

The first two lab periods will deal with transformers and are designed to reinforce theory you have had in previous courses. They will also give you time to reach a level of sophistication in your machinery lectures that will allow meaningful lab work on machines.

The lab procedures and details of what and how you will perform in the lab are purposely vague. You will be told what, in general, you are to do. You will design the experiment and make up a plan to be followed in the lab in order to obtain the data you will need.

The "data you will need" is that data necessary for you to do an analysis of behavior based on the theoretical approach and compare it with the behavior you observe in the actual machine. The comparison of theoretical and observed results must include conclusions and explanations, if possible, of discrepancies.

The plan referred to above will be accomplished prior to coming to the lab. It will include not only what but how you will proceed. You must have connection diagrams, resistor or rheostat ratings, instruments (including ratings) that will be used, etc.

The laboratory plan will be entered in a non-loose leaf type notebook. Data obtained as well as the write up of what you do, observations and conclusions will also be kept in this book. Do not remove pages or erase if you make mistakes. Merely line through the erroneous data.

The reason for this is to encourage you to do neat work and to think before you act. It is the customary procedure in industry. Patents, court litigation, etc. may depend upon the lab notes you maintain while working in industry.

You must obtain the lab instructor's Okay on your plan before proceeding with actual lab work.

TRANSFORMERS

Experiment 1

Transformer Ratio and Polarity

The object of this experiment is to study the various connection ratios of transformation that can be obtained with a multiple winding transformer.

The relative polarity of the windings in a transformer must be known before proper series or parallel connections can be made. Such connections are used because the primary or secondary sides of a transformer often have two windings, or because it may be desirable to make auto-transformer connections.

Two coils are connected cumulatively when they magnetize the common part of the coils in the same direction, and differentially when the directions of magnetization are opposite. If these coils are connected in series, with only one of them energized, the voltage appearing across the combination is equal to the algebraic sum of the two coil voltages. Applying this idea, the relative polarity of the various windings of a transformer can be determined by the use of a voltmeter.

Proceed with the experiment as follows:

1. Draw a diagram showing the windings of the transformer with their terminal markings, and obtain all name plate information.
2. To determine the various turns ratios, energize one winding of the transformer with its rated voltage and measure the voltages induced in the remaining windings.
3. By the method explained above, determine the relative polarity of all the windings.
4. Energize the transformer at reduced voltage (i.e., 110 volts on the 220 v side), and insert a fuse wire in one of the input lines. Record the voltages appearing across the output terminals when the two secondary windings are connected as follows:
 - a. Series cumulative,
 - b. Series differential,
 - c. Parallel cumulative, and
 - d. Parallel differential.

In the report, show a diagram indicating the turn-ratios and polarities of all windings. Also, discuss the results of Part 4.

TRANSFORMERS (Cont'd)

Experiment 2

The Transformer Equivalent Circuit

The purpose of this experiment is to determine the equivalent circuit of the transformer. When this is done, one may calculate important quantities associated with transformer operation, such as voltage regulation, efficiency, and phase shift. The same transformers as were used in the previous experiment will be studied here, so that all the name-plate data should be known.

As one step in the procedure, the winding resistance of both the high and low voltage sides should be obtained. To do so, apply DC and measure the proper voltage and current, with the latter approximately equal to rated value. Devise a scheme for securing rated current. Keep in mind that if these readings are taken at the beginning of the experiment, they correspond to the resistance at ambient temperature, and operating temperature.

With the high side of the transformer excited, take the necessary data for an open-circuit test, at rated voltage, and for a short-circuit test at 50, 100, and 150 per cent of rated current. As a check, excite the low side and take similar open and short-circuit data.

When taking the short circuit data, start with a very low applied voltage, since very high currents will otherwise occur on short circuit. Be sure to use current transformers throughout.

Before coming into the laboratory, the student must prepare circuit diagrams showing the proper instruments and their position. Since high currents may flow, it will be necessary to use current transformers with the ammeters and wattmeters. As always, shorting switches must be used.

The report of this experiment should include at least the following:

1. Calculate the copper losses in each winding under no-load and full-load conditions and discuss these.
2. Calculate the core loss from the no-load data.
3. Tabulate the following in per cent of their rated values; no-load current and power, core losses, and full-load copper losses on both sides of the transformer.
4. Calculation of the exact equivalent circuit parameters, based on the tests for both the high and the low sides.

5. Using the approximate equivalent circuit, calculate the voltage regulation for the following load conditions:
 - a. Rated load at unity power-factor,
 - b. Rated load at 0.8 power-factor lagging,
 - c. Rated load at 0.8 power-factor leading.

6. Calculate the efficiency at the three values of current used in the short-circuit test, assuming the power factor conditions given in 5.

INTRODUCTORY COMMENTS

MACHINES AND TORQUEMETERS

The majority of the experiments in this course will utilize the "universal" machine type of equipment and a few introductory comments are in order. A schematic diagram of the M-G set is attached. Each of the laboratory sets consists of two identical machines. The machines have a torque meter unit in the coupling between the machines and a tachometer at each end. The output of the torque meter is fed to a torque meter exciter and read-out box. Connection is made by a four-prong plug. One tachometer is a permanent magnet, single phase, alternating current generator operated over the linear portion of the magnetizing characteristic. There are some a.c. voltmeters calibrated in rpm for use with this. In some of our work we will be recording speed. We will then use the other tachometer; a small permanent magnet type d.c. generator whose induced voltage is proportional to speed. Some notes on calibration of the torque meter and the tachometer will be presented in what follows.

Each Universal machine consists of windings on the stationary member, or stator and the rotating member, or rotor. The windings on the stationary member are designated f_1-f_2 and f_3-f_4 . These windings are concentrated windings and the mmf resulting from these windings acts along the same axis. Each of these windings is rated 120 volts d.c. Thus the two windings can be placed in series by interconnecting f_2 and f_3 and excited from a 240 volt d.c. source. The windings on the rotor, or rotating member, are distributed. The windings are tapped at 120° intervals and brought out through slip rings to terminals M_1 , M_2 , and M_3 . The other end of the rotor has a commutator and brush arrangement and the winding is brought out from the brushes through terminals marked A_1 and A_2 . If we excite the slip rings with an a.c. voltage of 3 phase, a revolving magnetic field is established. If the revolving field rotates backward at rotor speed, it is stationary with respect to the field established by the winding designated $F_1...F_4$. If we excite the rotor through the terminals A_1 and A_2 with d.c., the commutator serves a switching function and allows proper direction of current flow through the armature inductors. When the machine is rotating, the commutator switching renders the resulting field stationary. The magnetic field associated with this stationary field is in quadrature with the field established by the winding of the stator. Thus we have a machine which can be operated on either a.c., or d.c., depending upon the external connection. It should be noted that, when operated as an a.c. machine, it is "inside out" compared to conventional a.c. machines.

When we operate the machine as a d.c. motor, we must either use a d.c. starter or reduced voltage d.c. on the armature in order to keep in-rush current within a reasonable value. After the initial in-rush of current, the motor starts gaining speed and the counter emf, $\omega L_d f f$ develops. This serves to limit the current. However, at 0 r.p.m. the resistance of the circuit is very low and a very high in-rush current would be experienced. The d.c. starter has the effect of putting full supply voltage across the field, or stationary winding in this machine, and inserting a resistance in series with the armature, or rotor. As the motor comes up to speed, the resistance in the armature circuit is gradually decreased until eventually it is all removed. The other choice is that we start with a very low value of adjustable voltage across the armature and gradually increase it as the armature comes up to speed. You will note that a d.c. starter is built into the terminal panel and the leads are marked L₁, L₂, A and F.

Schematically, the starter diagram is as shown below:

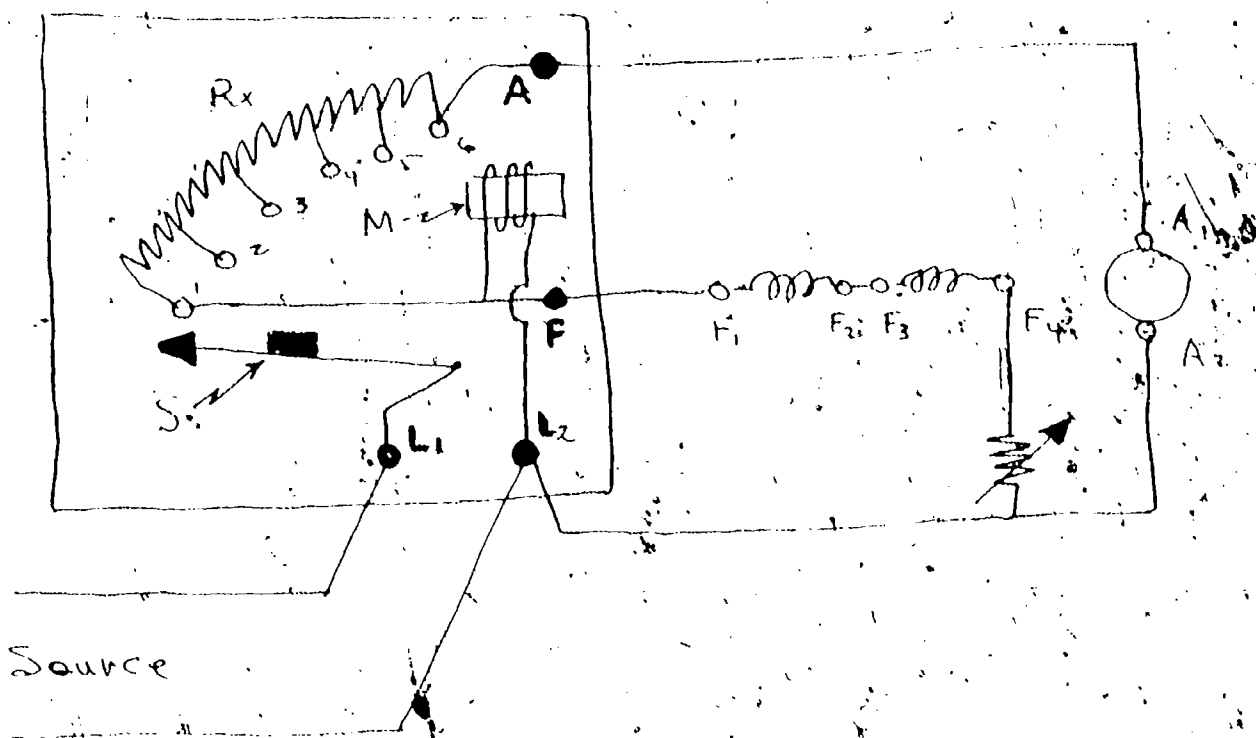

In this starter, the moveable arm, S, is held in its ccw position (off) by a spring. When S is moved to Stud #1, three circuits are closed. The first leads from L₁ through R_x through the armature to L₂. The second from L₁ through F to the shunt field to L₂ and the third from L₁ through the electromagnetic holding coil, M, to L₂. As the motor speeds up, arm S is advanced to cut out R_x in steps until full line voltage is across the armature. The resistance R_x is small relative to the resistance of the holding coil and the shunt field. When all of R_x is cut out, arm S is held in position at the final stud by the electromagnetic holding coil attracting the soft iron piece on S. If the voltage from the source falls to a low value or off completely, S is released and the motor is disconnected. This feature is referred to as "under voltage protection".

The machine rating is as follows:

poles: 2
 speed: 3600 rpm max.
 field rating (each field): approx. 250 ohms
 0.4 amperes

armature rating:

On A.C. (terminals M_1, M_2, M_3)
 150 volts, 6.7 amperes per terminal

On D.C. (terminals A_1, A_2)
 240 volts, 4.2 amperes

To operate as an induction motor, connect the fields in parallel (F_1 to F_3 ; F_2 to F_4) and across a 1000 ohm resistor.

On the front of the panel, there are four circuit breakers - two on the left and two on the right. One on each side is marked a.c. and one is marked d.c. The a.c. circuit breaker is in series with the terminals M_1, M_2 and M_3 and the d.c. circuit breaker is in series with terminals A_1 and A_2 .

These machines are rated 1000 voltamperes. Therefore all your laboratory planning should make note of this and you should choose power supplies, meters, resistors, etc. to insure that the rating is not exceeded, on a continuous basis. However, it may be desirable to go as high as 150% of rating for short times. The laboratory instructor will discuss this in detail.

TACHOMETER CALIBRATION

It is permissible to observe speed by using one of the calibrated a.c. voltmeters marked in thousands of r.p.m. If the speed is to be recorded, it will be necessary to use the d.c. tachometer with the recorder. In this case it will be necessary that the d.c. tachometer is calibrated and this is best done by using the a.c. meter as a speed reference or by using a strobotac. This would result in a conversion factor relating recorder input voltage, or divisions, per r.p.m., or thousand r.p.m. You must use a filter, as described below, to filter out the noise voltage.

TORQUEMETER CALIBRATION

Various read out devices can be used. If a pen recorder, or CRO, are used, the output of the torque meter must be filtered. The general filter has the following configuration.

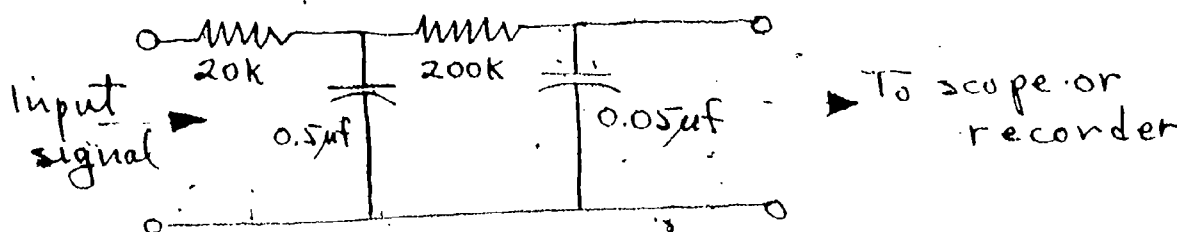

NOTE: If a voltmeter read-out is used, the input impedance must be greater than 20K ohms per volt. Appropriate ranges are 0-1.5/0-5 volt d.c. The black terminal may be connected to the lab ground to reduce pick-up.

The torque meter should be calibrated before each experiment, using the following procedure:

1. The Torquemeter should be allowed to warm up for about 10 minutes before it is used.
2. For most laboratory experiments, the "gain" adjustment knob should be set at maximum, i.e., turned fully clockwise.
3. The bias knob should then be adjusted so that the read-out meter has any suitable voltage reading for zero torque, preferably zero voltage.
4. At zero torque, it will be found that the Torquemeter reading varies, with rotor position, over a range of about ± 0.03 volts due to bearing friction induced torques. The reading for zero torque should, therefore, be determined by hand turning the rotor in both directions and selecting the mean value.

5. Insert the rotor lock bar on one side of the torquemeter element and the weighted rod on the other in the holes provided. Read the meter and the scope to determine a scale factor, i.e., so many ft.-lbs. per volt, or division. The devices will then read linearly over a range of ± 8 ft. lbs. (within 5%).
6. If, for any reason, the gain setting is changed, the bias voltage for zero torque must be readjusted and the calibration of the torquemeter must be repeated.

NOTE: A gain of approximately 0.3-0.5 volts per ft.-lb. should be obtained.



DC MACHINES

Experiment 3

Obtaining Machine Parameters

The object of the next three experiments will be to compare observed performance of an actual d.c. machine with the performance one would predict from the linearized equations derived in the lecture and using values of machine parameters, or constants, determined from test results.

In order to do a mathematical analysis, you will need information on the various resistances, inductances, the friction and windage loss, and the moment of inertia.

Measurement of Resistance and Inductance

The resistance as measured between the armature terminals of a DC machine is composed of two distinct components: one component is the resistance of the copper winding, and the other is the combined resistance of the carbon brushes and the brush contact. The resistance of the copper is independent of current density and hence is constant (provided the temperature is constant). Except for very low or very high current densities the resistance of the carbon varies approximately inversely as the current density. Typical variations of these component resistances with respect to current density, together with the sum, are shown by the curve immediately below.

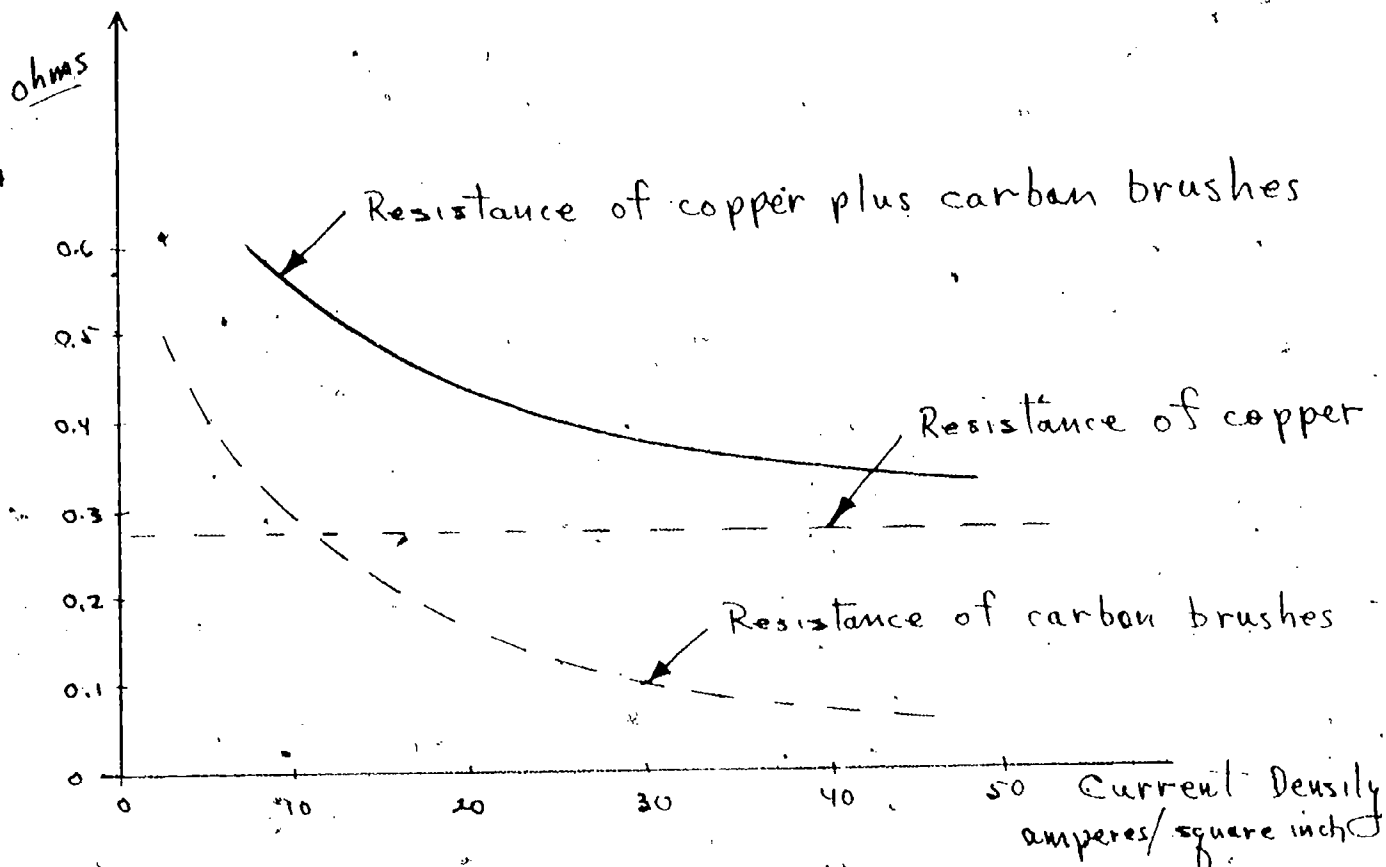

The fact that the total armature resistance drop under changing load conditions is variable makes it desirable to separate this drop into brush and copper components. If the resistance of the carbon brush in contact was inversely proportional to the armature current, the brush drop would be constant regardless of armature current and the brush drop line would be horizontal when plotted against current. However, this drop is not constant. The variation for a typical machine under running conditions is shown immediately below.

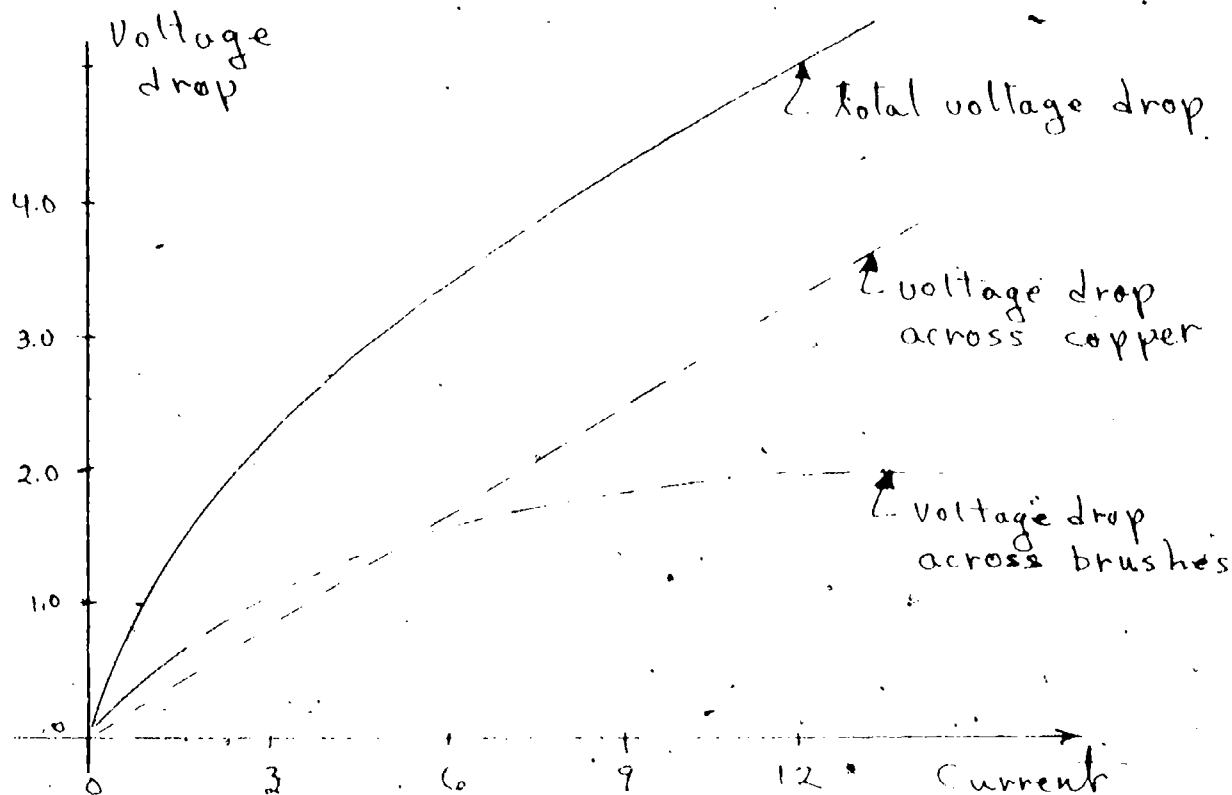

The Institute of Electrical and Electronic Engineers standards state that the total positive and negative brush drop (carbon brushes with pigtailed attached) is to be taken as two volts. One volt is for the brush set to which current is in the armature and the other is for the brush set through which current leaves. This would indicate that the brush drop for all machines is two volts. Such is not the case, however, under typical operating conditions of brush pressure and temperature the combined drops for positive and negative brushes may approach as high as four volts. The brush drop current obtained with the machine running is also different from that obtained with the armature stationary. The test circuit for measuring the brush drop is as follows:

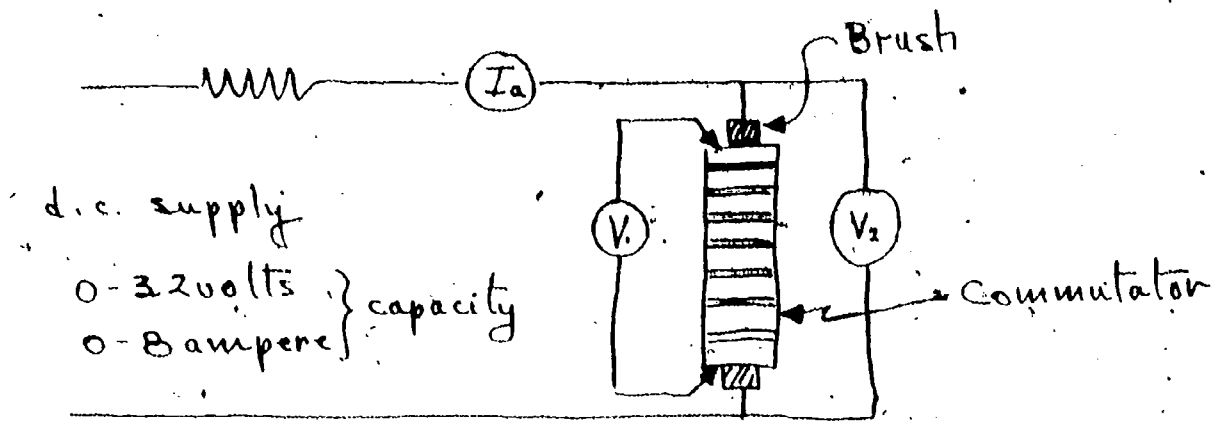

V_1 - measures voltage drop across armature copper

V_2 - measures voltage drop across armature copper plus the drop across the carbon brushes.

The voltage drop across the armature terminals and the voltage drop across the copper winding for the universal type machines was measured with the armature stationary for various values of armature current ranging from zero to about 125% of rated full load current. The winding was allowed to come to thermal equilibrium before beginning the test so that the temperature changes during the test were negligible. This was accomplished by passing current through the winding for a period of time prior to the test. The rotor was blocked so it did not tend to accelerate under the influence of residual magnetism. The test information obtained was:

I_a	V_1	V_2
2	7.2	7.6
4	13.7	14.2
6	21.3	21.8
7	22.8	24.3
8.7	28.1	29.6

From this information, calculate r_a , armature circuit resistance and a more or less constant value of voltage drop across the brushes to subtract from the applied voltage. The net voltage is the voltage that is actually impressed across the armature of the motor.

The inductance of the machine was measured in a similar fashion by using a Variac, rather than a DC supply, and energizing the same kind of circuit (as used for resistance measurement) from a 60 cycle source. From readings V_1 and I_a it should

be possible to calculate the impedance of the armature circuit. Based on the information taken from the resistance measurements, you can then calculate the 60 cycle inductive reactance. This can be then converted into henries of inductance.

The a.c. readings were: (at 60 cps)

I_a	V_1
1.0	20.3

From this information calculate L_a .

In order to determine r_f and L_f , a step voltage was impressed on the winding F_1-F_2 (note that this is only one of the two field windings). The circuit used for this measurement was as follows:

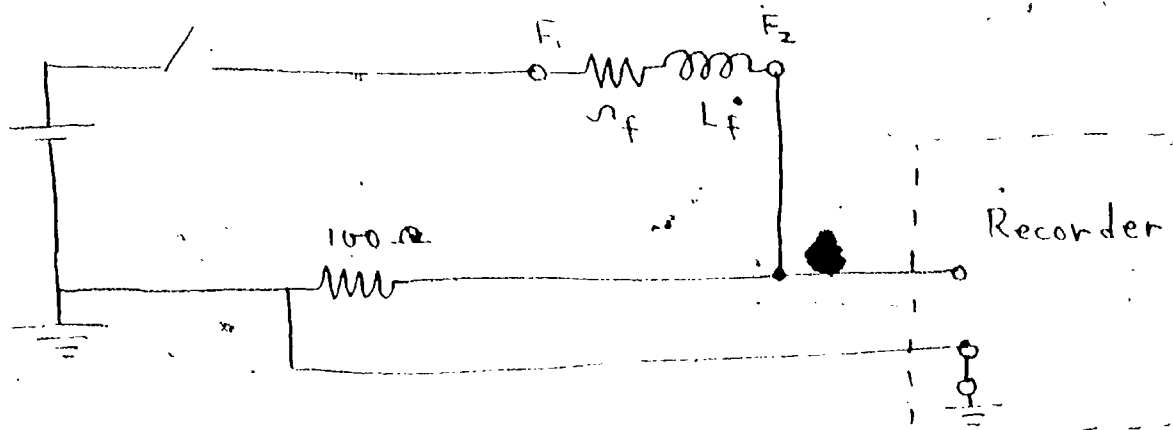

Data obtained from the recording is:

<u>time, seconds</u>	<u>V_r</u>
0.04	4 volts
0.08	5.5
0.16	6.9
0.24	7.8
0.32	8.2
0.40	8.5
∞	9.1

From this data, find r_f , L_f .

The above should be accomplished prior to coming to the laboratory. The lab instructor will discuss the physical configuration of the machines before you commence lab work.

In this lab period, you will measure the friction and windage torque (mechanical), the moment of inertia of the set, and the value of L_{df} .

Measurement of Friction and Windage

The torque meter measures torque transmitted via the shaft which connects the two machines. If the field of one machine is unexcited or unenergized, the torque measured as the speed is varied from zero up to, say, 2000 rpm will enable you to plot T_{f+w} as a function of speed. This information will be necessary when you determine J , the moment of inertia. For this "no load" test, connect the machines as shown.

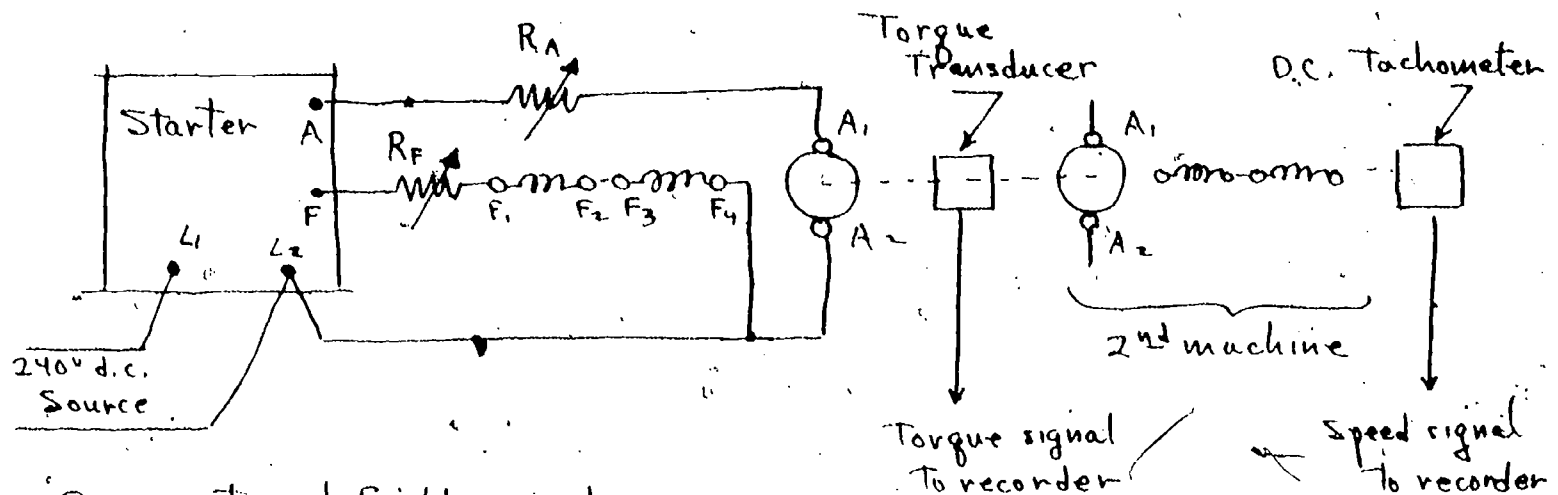

R_F - external field resistor
 $\approx 0-1000 \Omega$

R_A - external armature resistor
 $\approx 0-25 \Omega$

Note: Use filter on output of torque and speed transducers.

Speed is varied by varying the external resistors. Increasing the resistance in the armature circuit tends to slow the driving machine down, increasing resistance in the field circuit speeds it up. From the steady state performance equations you should be able to figure this out!

Measurement of Inertia

If you have measured $T_{f+w}(\omega)$, you can assume that the total $T_{f+w}(\omega)$ (for the two machines) is twice what you measured for the single unit (the machines are identical). Now, if you have one machine driving the complete set and you deenergize it, it will coast to a stop. The $T_{f+w}(\omega)$ is the torque that causes it to retard in speed. Mathematically, for this situation;

$$J \frac{d\omega}{dt} + T_{f+w}(\omega) = 0$$

or

$$J = - \frac{T_{f+w}}{\Delta\omega/\Delta t}$$

for small increments of ω . If you record $\omega(t)$ after deenergizing, you can find $\frac{\Delta\omega}{\Delta t}$ and, from T_{f+w} corresponding to ω over the interval, calculate J.

Measurement of L_{df}

The d.c. shunt connected machine corresponds to a generalized machine except there is no G winding nor is there a D winding. The F winding corresponds to the field winding and the Q winding corresponds to the armature winding. The generalized equations become, from (III-99) through (III-108):

$$v_f = r_f i_f + L_f \frac{di_f}{dt}$$

$$v_a = r_a i_a + L_a \frac{di_a}{dt} + \omega L_{df} i_f$$

where the subscript "a" is used (for armature) rather than q.

If the field current is constant,

$$i_f = \frac{v_f}{r_f}$$

and if the armature circuit is on "open circuit", i.e., $i_a = 0$.

$$v_a = \omega L_{df} i_f$$

Thus by measuring ω , v_a , and i_f we can obtain L_{df} . This is to be done for values of ω corresponding to the range from as slow as possible up to around 2000 rpm.

DC MACHINES (Cont'd)

Experiment #4

Transient Behavior of the DC Shunt Motor

Based on the machine data you have obtained thus far, you can obtain the theoretical performance of the d.c. machine connected as a separately excited shunt motor energized by a step function voltage impressed on the armature. We cannot obtain a step function of voltage using a d.c. starter box because it inserts resistance in steps. We cannot impress rated line voltage because of the high inrush current. In order to keep the inrush current to an acceptable value (5-8 times rated) we will energize the machine with reduced voltage. We obtain this reduced voltage by means of rectification of a three phase supply. We will use, for the supply, the 3 phase, 4 wire 120 volt (line-line) supply in the lab. Our rectifier, a half wave, 3 phase, rectification connection, is as follows:

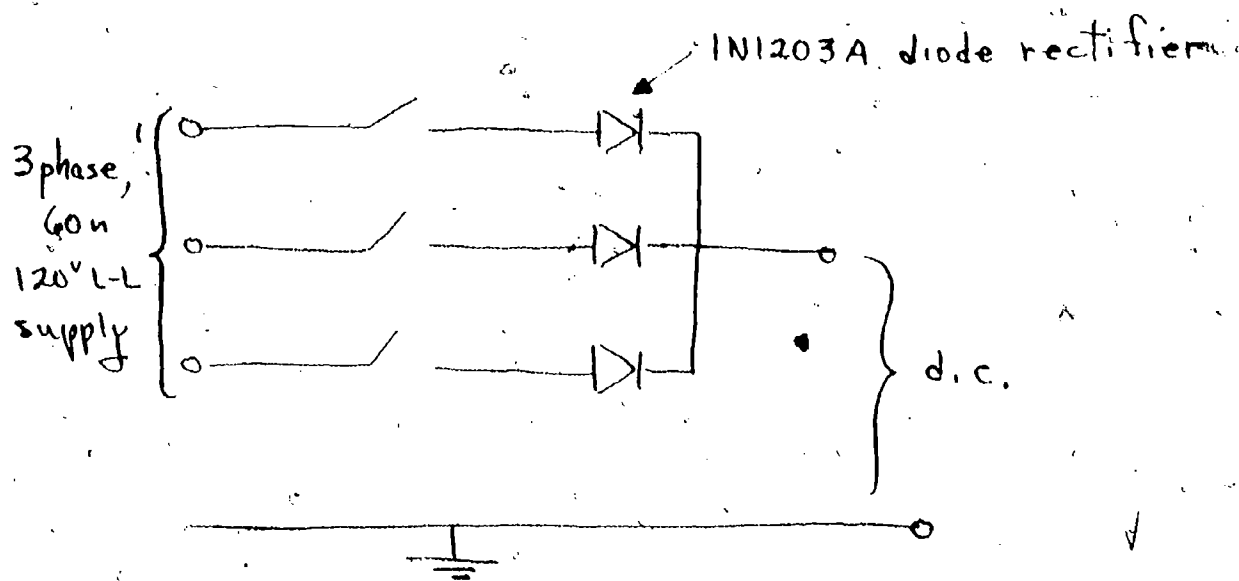

The IN1203A rectifiers are rated as follows:

max. peak reverse voltage	300 volts
max. forward current	12 amperes average
max. 1 cycle peak surge current	240 amperes
forward voltage drop at 12 amperes	1.35 volts

Note that each phase rectifier will conduct current only when the potential of that particular phase is greater than that of the other phases. As that phase voltage decreases, the next phase voltage will be increasing and the current will transfer to the increasing phase when the increasing phase voltage exceeds that of the previously conducting phase. This can be shown graphically as follows:

PAGE 16a "SKETCH OF THE SCHEMATIC DIAGRAM FOR THE UNIVERSAL
MACHINE MG SET" REMOVED DUE TO OVERSIZE.

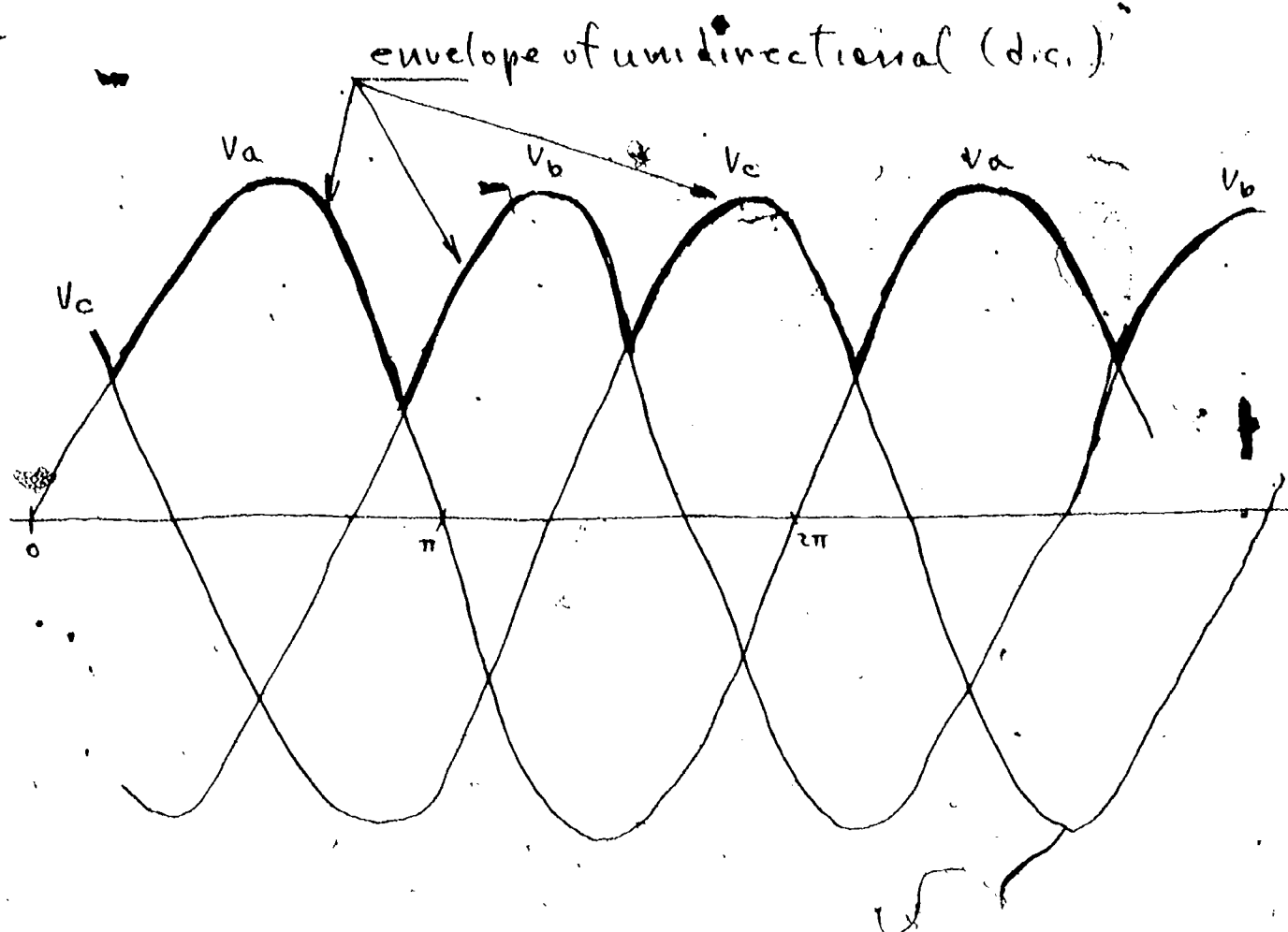

The rectifier in phase a conducts during the period:

$$v_c \leq v_a \text{ and until } v_a \leq v_b$$

conduction ends when:

$$V_m \sin \omega t = V_m \sin (\omega t - 120)$$

or:

$$\sin \omega t = \sin \omega t \cos 120 - \cos \omega t \sin 120$$

$$\frac{3}{2} \sin \omega t = -\frac{\sqrt{3}}{2} \cos \omega t$$

Now;

$$\sin 150^\circ = 1/2; \cos 150^\circ = -\frac{\sqrt{3}}{2}$$

and;

$$\left(\frac{3}{2}\right)\left(\frac{1}{2}\right) = \left(-\frac{\sqrt{3}}{2}\right)\left(-\frac{\sqrt{3}}{2}\right)$$

The rectifier conducts for $150^\circ - 90^\circ = 60^\circ$ beyond the maximum value of phase a. By symmetry, it conducts 60° before the maximum. Thus each rectifier conducts for 120° of each cycle. The average voltage (d.c.) can be calculated as:

$$V_{dc \text{ average}} = \frac{1}{2\pi/3} \int_{\pi/6}^{5\pi/6} V_{\max} \sin \omega t \, d(\omega t) = \frac{3\sqrt{3}}{2\pi} V_{\max} = \frac{3\sqrt{3}}{2\pi} \sqrt{2} V_{\text{rms}}$$

If the line to line voltage is 120, the line-neutral voltage is $\frac{120}{\sqrt{3}}$ and the average value of d.c. voltage is:

$$\frac{3\sqrt{3}}{2\pi} \sqrt{2} \times \frac{120}{\sqrt{3}} \approx 80 \text{ volts}$$

The peak inverse voltage is a very important rating of diodes that must be observed. In order to determine the peak inverse voltage that will be impressed upon the diodes in this connection, note that when the rectifier in phase a is conducting, the voltage on the anode in phase c, for example, is negative. This is inverse, or reverse voltage.

Its magnitude is:

$$\begin{aligned} \text{Inverse voltage} &= v_a - v_c \\ &= V_m \sin \omega t - V_m \sin (\omega t - 240) \end{aligned}$$

to find the maximum, or peak, denoted as PIV:

$$\frac{d(\text{Inverse Voltage})}{d(\omega t)} = V_m \cos \omega t - V_m \cos (\omega t - 240) = 0$$

or

$$\cos \omega t = (\cos \omega t)(\cos 240) + (\sin \omega t)(\sin 240)$$

$$\frac{3}{2} \cos \omega t = -\frac{\sqrt{3}}{2} \sin \omega t$$

from which: $\tan \omega t = -\sqrt{3}$

and:

$$\omega t = 120^\circ$$

Using this value,

$$\text{PIV} = V_m \sqrt{3}$$

Note that we will have a "ripple" voltage of fundamental frequency which is three times that of the supply frequency.

Grounding Precautions

In using the recorder to record various variables which we desire, it will be necessary to be careful in connecting the "ground" terminal of the recorder to make certain that we do not connect two supposed "grounds" which are actually at different potential.

In order to compare actual transient performance with theoretical performance, you should write and solve the theoretical equations using parameters from Experiment 3. In this period we will obtain the actual performance. The supply and recorder should be connected as follows: (Grounded low signal circuits are required for noise considerations).

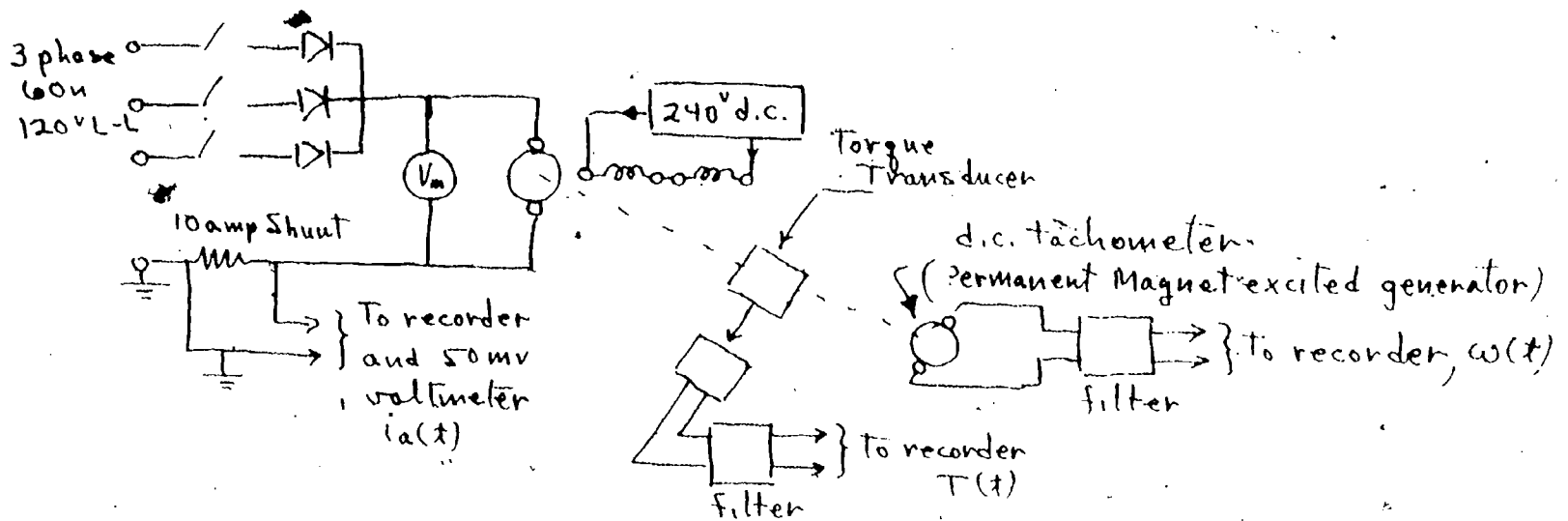

At $t=0$, with all resistance removed from the field of the motor, close the rectifier supply switch and record $\omega(t)$, $i_a(t)$, $T(t)$, and $V_{d.c.}$. Plot both the experimental and theoretical results on the same sheet; account for discrepancies.

DC MACHINES (Cont'd)

Experiment #5

DC Shunt Motor Steady State Speed-Torque Characteristic

Connect the motor to the regular 250 volt supply (watch "grounds" on your instrumentation) through a d.c. starting box and with a variable rheostat (say 0-10 ohms) in series with the armature and a 250 ohm rheostat in the field circuit. Connect the other machine as a generator and arrange to load it by connecting a load bank across its terminals. Then make several runs to determine the steady state speed-torque characteristics of the motor under various situations. For example, make runs with both rated and decreased armature voltage, with and without external armature resistance and with various values of field current.

Use your imagination in devising the exact situations you will examine. The main idea is to see the effect of varying the various parameters on the steady state speed-torque characteristic of the motor. Compare your test results with analytical results.

Always make certain that the field circuit is energized when connecting the armature to the supply. Also, note that the starting box cannot be used when reduced voltage is impressed. Why? Discuss these points in your lab report.

It is appropriate at this time to consider further the problem of grounding and ground connections involving the lab power supplies and instrumentation.

The lab voltage system is as follows:

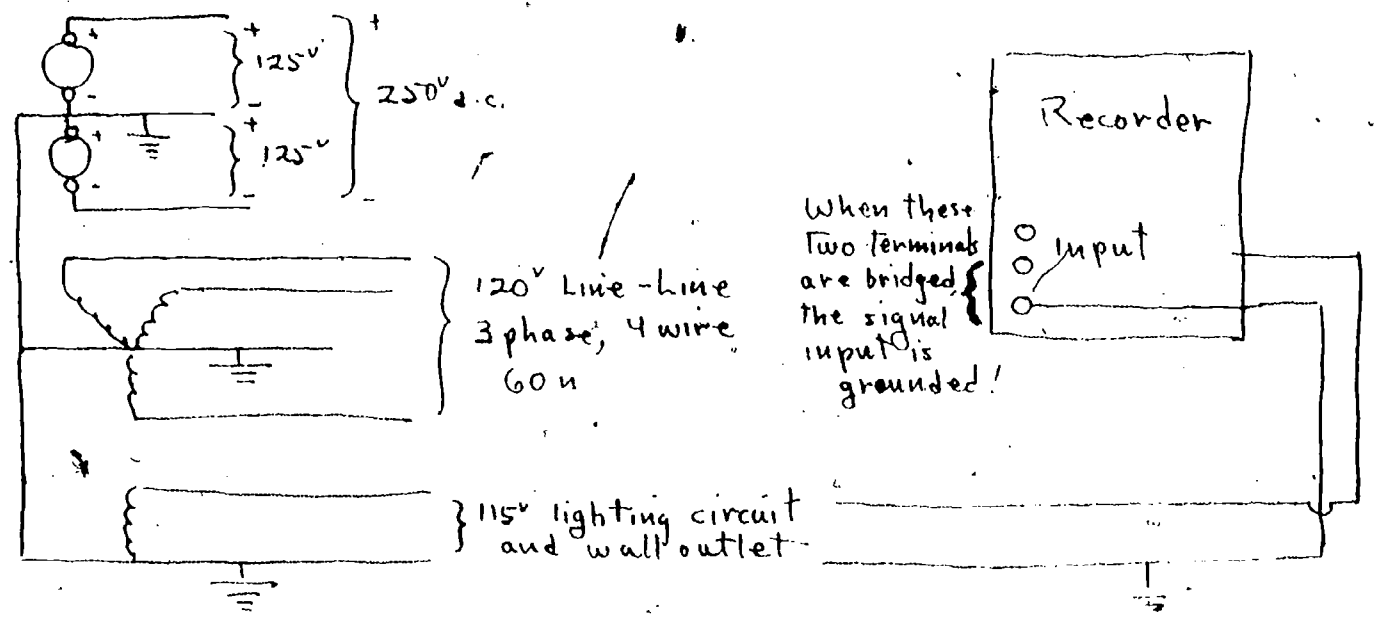

If it is desired to record field current of a d.c. machine, such as one of our lab motors, some means must be devised to energize the armature and starting box from 250 v (because that is the rated voltage of the holding coil in the starter) and yet have a grounded supply (125 v) to the field circuit. This can be done with machines which have two shunt fields normally connected in series with 250 v. Connection is made to L_1, L_2 and A. This puts 250 v on the starting box holding coil. The field windings are paralleled and connected between L_2 and the "center tap" or ground of the d.c. supply. Since we are working with low level signals into the recorder, the grounded input connection is desirable to reduce "hum". Such a connection is shown below:

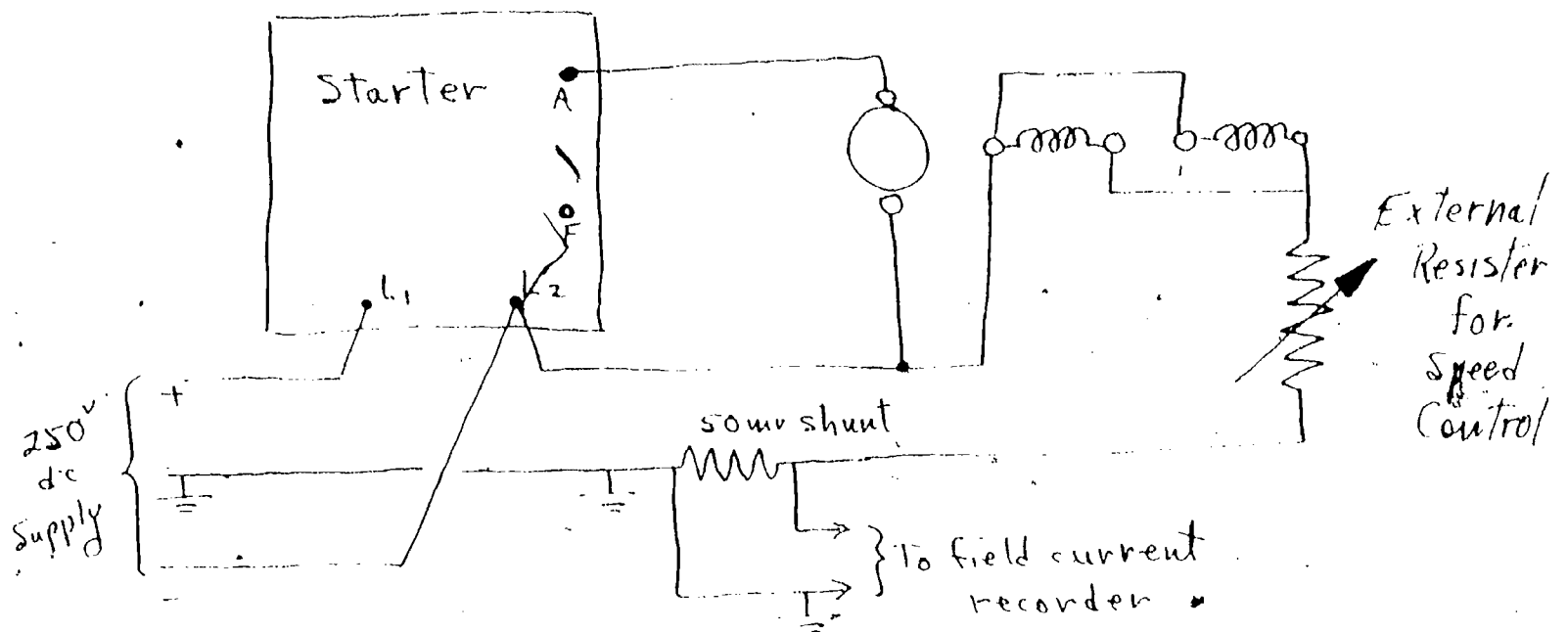

It is often necessary to exercise ingenuity in arranging instrumentation. It is always necessary to exercise caution in connecting grounds!

DC MACHINES (Cont'd)

Experiment #6

The DC Shunt Connected Generator

This experiment will enable you to see how the machine behaves when connected as a generator. Connect one machine to run as a separately excited d.c. motor to be started through a starting box. The other machine will be connected as a separately excited d.c. generator with provision to adjust generator field current. Obtain steady state characteristics of terminal voltage vs. load current as load is varied from zero up to a value which yields about 150% of rated load current. Examine the effect of various field excitations, etc. Also, connect up and record transient data pertaining to the switching on of full load when the machine is initially unloaded. Use your imagination in designing your experiment so that you can obtain data which you can compare to analytical analysis and from which you can draw meaningful conclusions.

CROSS FIELD MACHINES

Experiment #7

Determining the Transfer Function of the Amplidyne

This portion of the laboratory work will concern itself with a "cross field" machine (metadyne) which is compensated and goes under the trade name "Amplidyne". The block diagram for the Amplidyne is based on equations (V-27) through (V-30). It is:

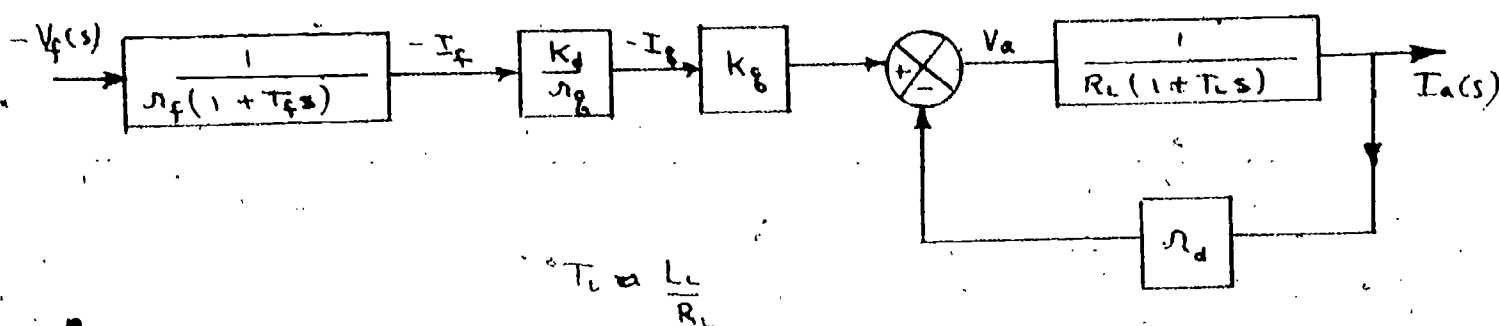

The transfer function for the Amplidyne is, from the block diagram:

$$\frac{I_a(s)}{e_f(s)} = \frac{KDKQ}{r_f r_q (r_d + R_L)} \frac{1}{(1 + T_f s)(1 + T_L s)}$$

where:

$$T_f = \frac{L_f}{r_f}; \quad T_L = \frac{L_L}{R_L + r_d}$$

This transfer function was obtained under the assumption that:

- the transformer voltages induced in one winding by current change in another winding are negligible.
- the time constants associated with the d, q, windings are negligible.
- $r_d \ll R_L$.

We can determine the transfer function for the output voltage as a function of input voltage by multiplying the function $\frac{I_a(s)}{V_f(s)}$ by $\frac{V_a(s)}{I_a(s)}$ which is the transfer function of the load. In our lab work, we will use a pure resistance for load,

i.e. $L_L = 0$. This will result in $T_L \approx 0$ and we will not mask exceptions to the assumptions we made in deriving our function $\frac{I_a(s)}{V_f(s)}$. We will be able to see how closely our linearized simplified model transfer function approximates the actual transfer function. Thus:

$$\frac{V_a(s)}{V_f(s)} \approx \frac{K_D K_Q}{r_q r_f (1 + T_f s)}$$

In the steady state, for $\omega T_f \ll 1$ and sinusoidal driving function, this ratio approaches the value:

$$\frac{V_a(i\omega)}{V_f(i\omega)} = K', \text{ for } \omega \ll \frac{1}{T_f}$$

Recall from control theory that, if $\omega T_f \ll 1$, there is negligible phase shift (or very nearly 180° shift) and thus the ratio of the instantaneous values is also the ratio of rms values.

Therefore

$$\frac{V_a \text{ rms}}{V_f \text{ rms}} \approx K'$$

To find the power gain, note that

$$\text{Power output} = \frac{V_a \text{ rms}^2}{R_L}$$

$$\text{Power input} = \frac{V_f \text{ rms}^2}{r_f}$$

$$\text{Power gain} = \frac{V_a \text{ rms}^2}{R_L} \frac{r_f}{V_f \text{ rms}^2} = K'^2 \frac{r_f}{R_L}$$

To obtain the value of T_f (and other time constants actually present within the machine) we will obtain data necessary to make a Bode plot.

First, the connection diagram to achieve this will be indicated. We will then discuss the Bode plot theory.

The connection diagram is as follows:

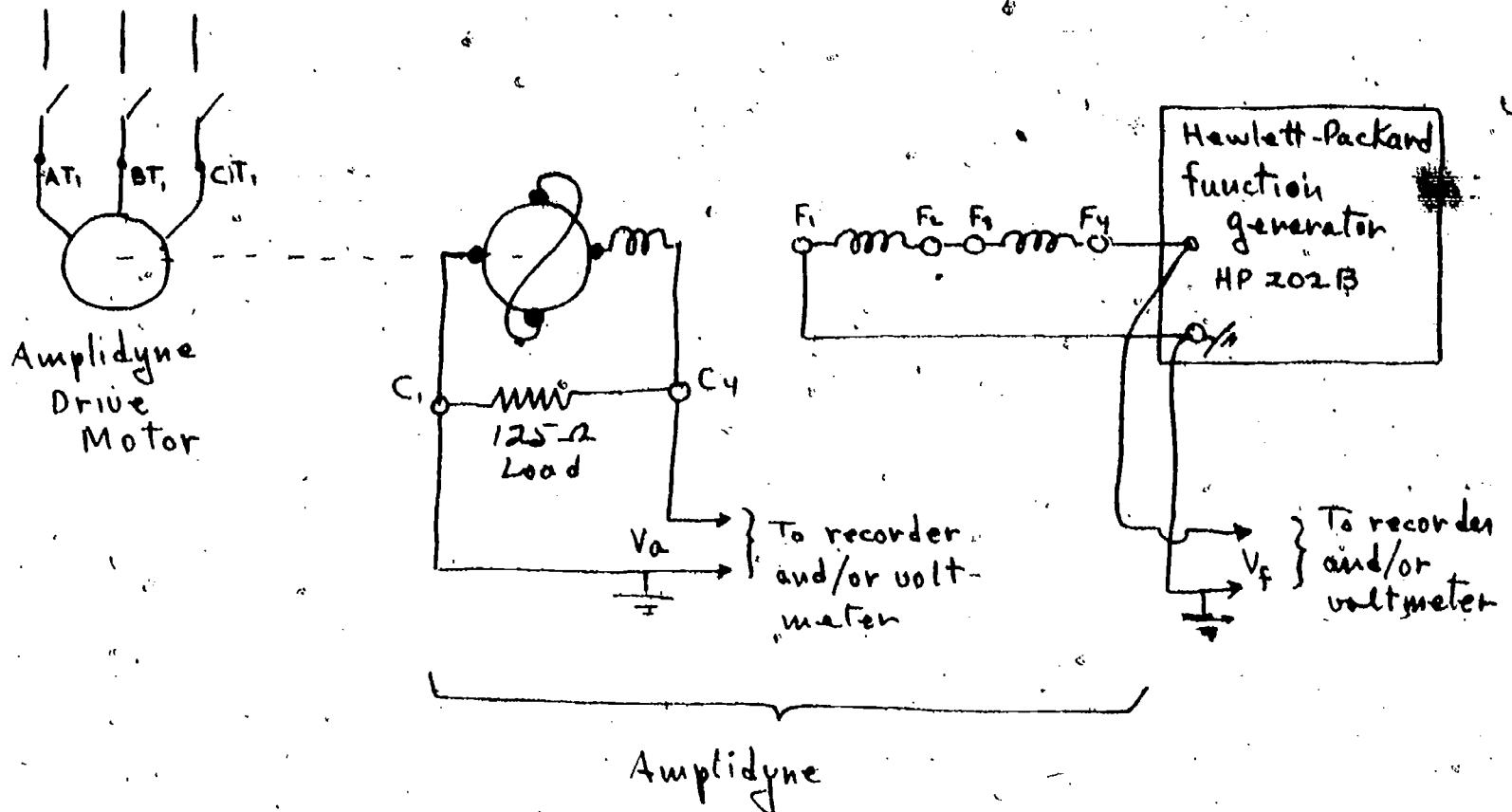

The Amplidyne is rated 250 volts, 500 watts output. Therefore rated load is 125 ohms. The function generator will go down to 0.01 hz and can provide either square, triangular or sinusoidal wave forms. We will use sinusoidal because that is the form upon which the theory of the Bode plot is based. After obtaining a calibration on the set up (so many divisions of recorder deflection corresponding to so many volts) we will be able to obtain $v_a(j\omega)$ and $v_f(j\omega)$. This enables us to make the Bode plot and determine the value of K' and the time constant(s) of the machine. We will examine the response in the frequency range from 0.1 to 40 hz. in accordance with the following theory.

Recall that, from circuit theory, if the driving force is a sinusoid we can obtain the relationship between input and output of a device by replacing s in the transfer function with $j\omega$. The transfer function then becomes:

$$\frac{v_a(j\omega)}{v_f(j\omega)} = \frac{K'}{1 + j\omega T_f}$$

Suppose in general we have a transfer function

$$W(j\omega) = \frac{K(1 + jT_1\omega)}{(1 + jT_2\omega)(1 + jT_3\omega)}$$

This is a complex variable expression which can be written:

$$W(j\omega) = |W(j\omega)| e^{j\psi}$$

If the input to the system is:

$$r(j\omega) = |r(j\omega)| e^{j\alpha}$$

and the output is:

$$C(j\omega) = |C(j\omega)| e^{j\beta}$$

then:

$$\frac{C(j\omega)}{r(j\omega)} = W(j\omega)$$

can be written as:

$$\frac{|C(j\omega)|}{|r(j\omega)|} e^{j(\beta-\alpha)} = |W(j\omega)| e^{j\psi}$$

The ratio of the magnitude of output to input is the magnitude $|W(j\omega)|$ and the difference in phase angle, i.e., the phase shift is equal to the phase angle associated with the system itself.

The relationship between the magnitudes can also be expressed as (for the general case above):

$$\begin{aligned} 20 \log_{10} \frac{|C(j\omega)|}{|r(j\omega)|} &= 20 \log_{10} |W(j\omega)| \\ &= 20 \log_{10} \left\{ \frac{K \sqrt{1 + (T_1\omega)^2}}{\sqrt{1 + (T_2\omega)^2} \sqrt{1 + (T_3\omega)^2}} \right\} \end{aligned}$$

By definition, the term on the left side is system gain in decibels. We will abbreviate this as

$$20 \log_{10} \frac{|C(j\omega)|}{|r(j\omega)|} = G_{db}$$

Then:

$$\begin{aligned} G_{db} &= 20 \log_{10} K + 10 \log_{10} [1 + (T_1\omega)^2] - 10 \log_{10} [1 + (T_2\omega)^2] + \\ &\quad - 10 \log_{10} [1 + (T_3\omega)^2]. \end{aligned}$$

We can obtain the value G_{db} by plotting individual terms on the right side and graphically adding them. The graphical plot will be system gain in db as the ordinate against $\log_{10} \omega$. $20 \log_{10} K$ is independent of ω and plots as a horizontal line. Thus:

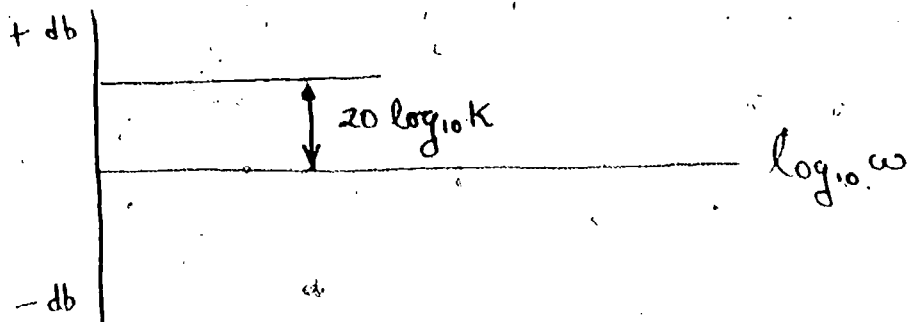

For the other terms, note that

$$10 \log_{10} [1 + (T_1 \omega)^2] \rightarrow 0 \text{ as } \omega \rightarrow 0$$

$$\rightarrow 20 \log_{10} \omega T_1 \text{ as } \omega \rightarrow \infty$$

On a $\log \omega$ scale, $20 \log \omega T_1$ is a straight line of slope 20 db per decade (unit of 10) of $\log \omega$. It intersects the zero db axis at:

$$\omega = \frac{1}{T_1}$$

We can approximate $10 \log_{10} (1 + \omega^2 T_1^2)$ then as follows:

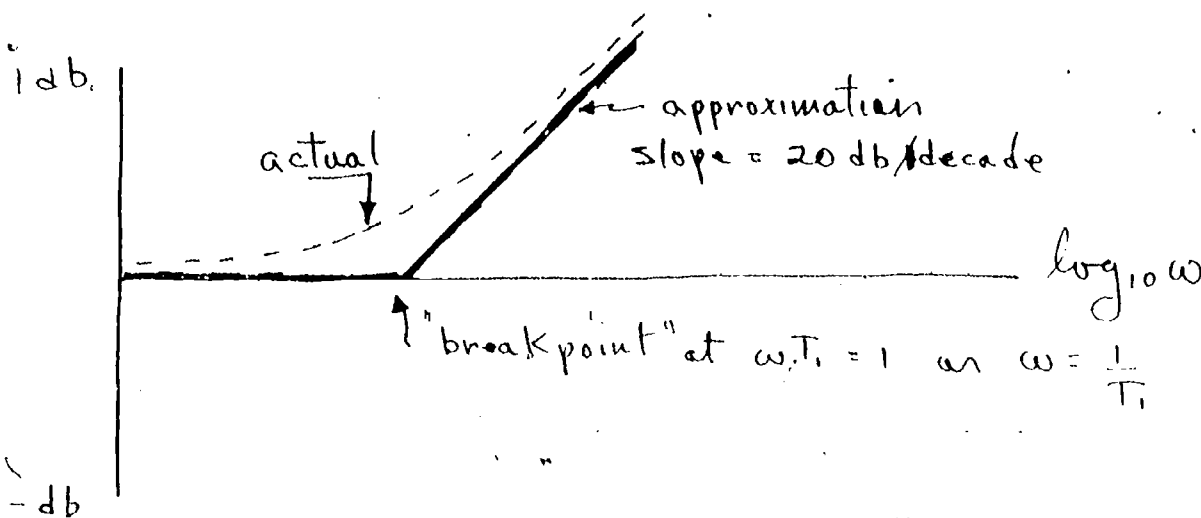

The plot for the other terms would be similar except the slope would be negative rather than positive.

If we had an experimental response curve, as shown below, we could use the above development to "work backward" and obtain the transfer function.

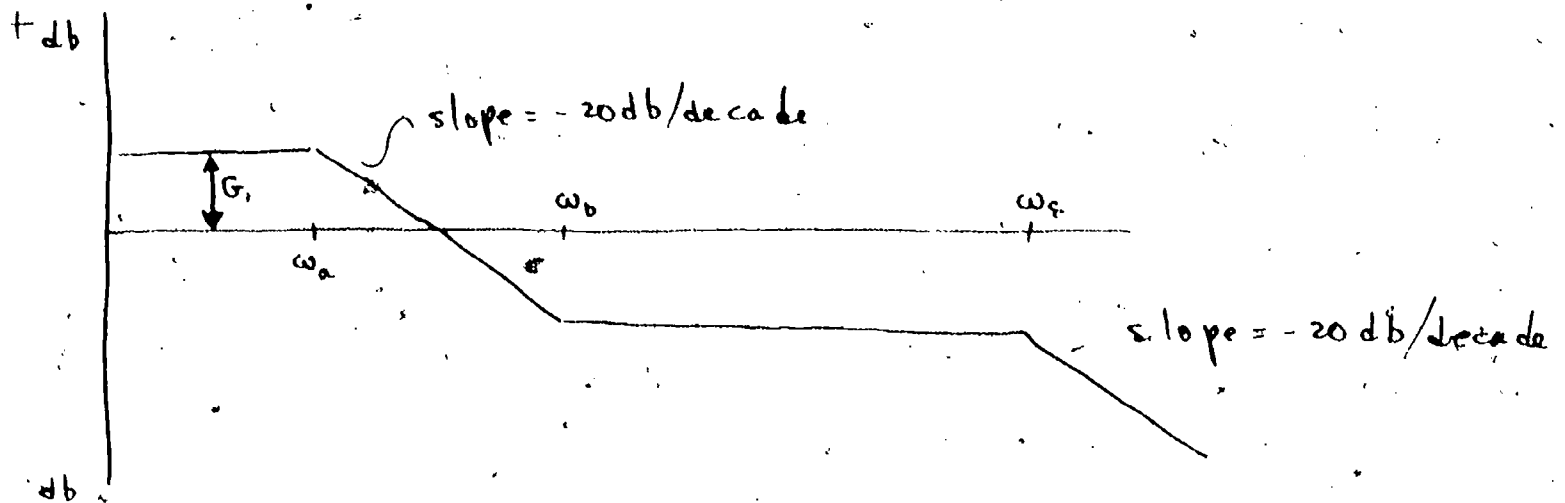

We would consider the actual curve to be composed of four separate and distinct curves, thus:

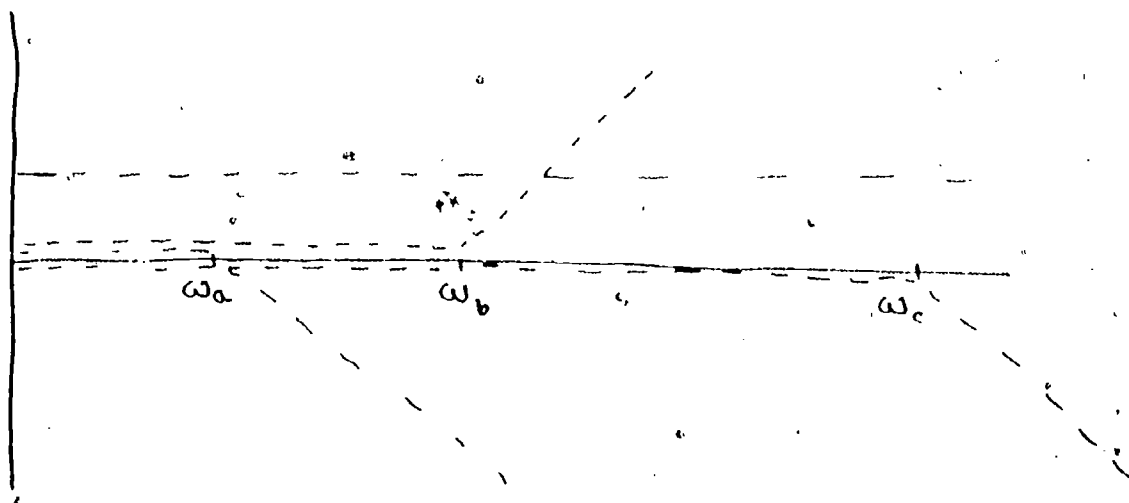

$$G_1 = 20 \log_{10} K$$

$$T_1 = \omega_b^{-1}$$

$$T_2 = \omega_a^{-1}$$

$$T_3 = \omega_c^{-1}$$

After determining the values T_1, T_2, T_3 and K we can write the transfer function! Thus, we can use this technique to determine the transfer function of the amplidyne.

In our experimental set-up, using a pure resistance for a load we would expect only 1 break point in the frequency response curve if our assumptions were completely correct. If we determine that there are additional breakpoints, we can determine the time constants we are neglecting. Discuss this completely in your report of this lab work. What is the time constant we are neglecting?

SYNCHRONOUS MACHINES

Experiment 8

Alternator Parameters

The equations which describe the synchronous alternator in the steady state are:

$$V_{ta} + I_a r + j I_d X_d - j X_q I_q = j E_f$$

and

$$E_f = \frac{\omega L_{df} I_f}{\sqrt{2}}$$

where

V_{ta} = terminal voltage, rms

I_a = armature current = $I_d + j I_q$

r = armature resistance

I_d = d axis component of I_a

I_q = q axis component of I_a

X_d = direct axis synchronous reactance = ωL_d

X_q = quadrature axis synchronous reactance = ωL_q

E_f = excitation voltage

I_f = field current

ω = angular velocity of the rotor

L_{df} = mutual inductance between d coil and field coil

Note that the parameters required are:

$$L_d, L_q, r \text{ and } L_{df}$$

The Institute of Electrical and Electronic Engineers Publication #115, March 1965, entitled, "Test Procedures for Synchronous Machines" details various test procedures for determining these, as well as other parameters. In general, only the details of the test are presented in this publication. Therefore some theory will be developed here in order to aid the student in making the tests.

The armature resistance can be obtained by measuring the IR drop across the winding when the winding is energized from a direct current source. The current value used should be that of approximately rated value and the winding should be brought to thermal equilibrium before the readings to be used for calculation are taken. The resistance, as measured, can be corrected to the resistance at a specified temperature by conventional procedures. Note that the lab machines are delta connected. The apparent resistance, R_m , and the phase resistance, r , are related by:

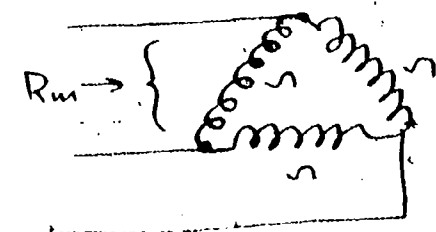

$$R_m = \frac{r(2r)}{r + 2r}$$

or:

$$r = \frac{3 R_m}{2}$$

L_{df} is obtained from the "open circuit saturation curve". If the armature is on "open circuit", I_a , I_d and I_q are zero and, from the steady state equations,

$$L_{df} = \frac{\sqrt{2} V_{ta}}{\omega i_f}$$

The "open circuit saturation curve" is a curve of armature terminal voltage (on open circuit) as a function of field current when the machine is running (being driven) at rated speed. If saturation were not present, this curve would be a straight line. However, saturation is present at higher values of field current and the curve does bend over reflecting the effect of saturation.

Wiring Diagram 8-1 depicts the connection diagram used to obtain this characteristic as well as to obtain the "short circuit saturation curve".

The figure below shows typical open circuit and short circuit saturation curves. If saturation was not present, i.e., no iron, only air, the open circuit curve would be straight. Therefore, a straight line extension of the actual open circuit characteristic is referred to as the "air gap line".

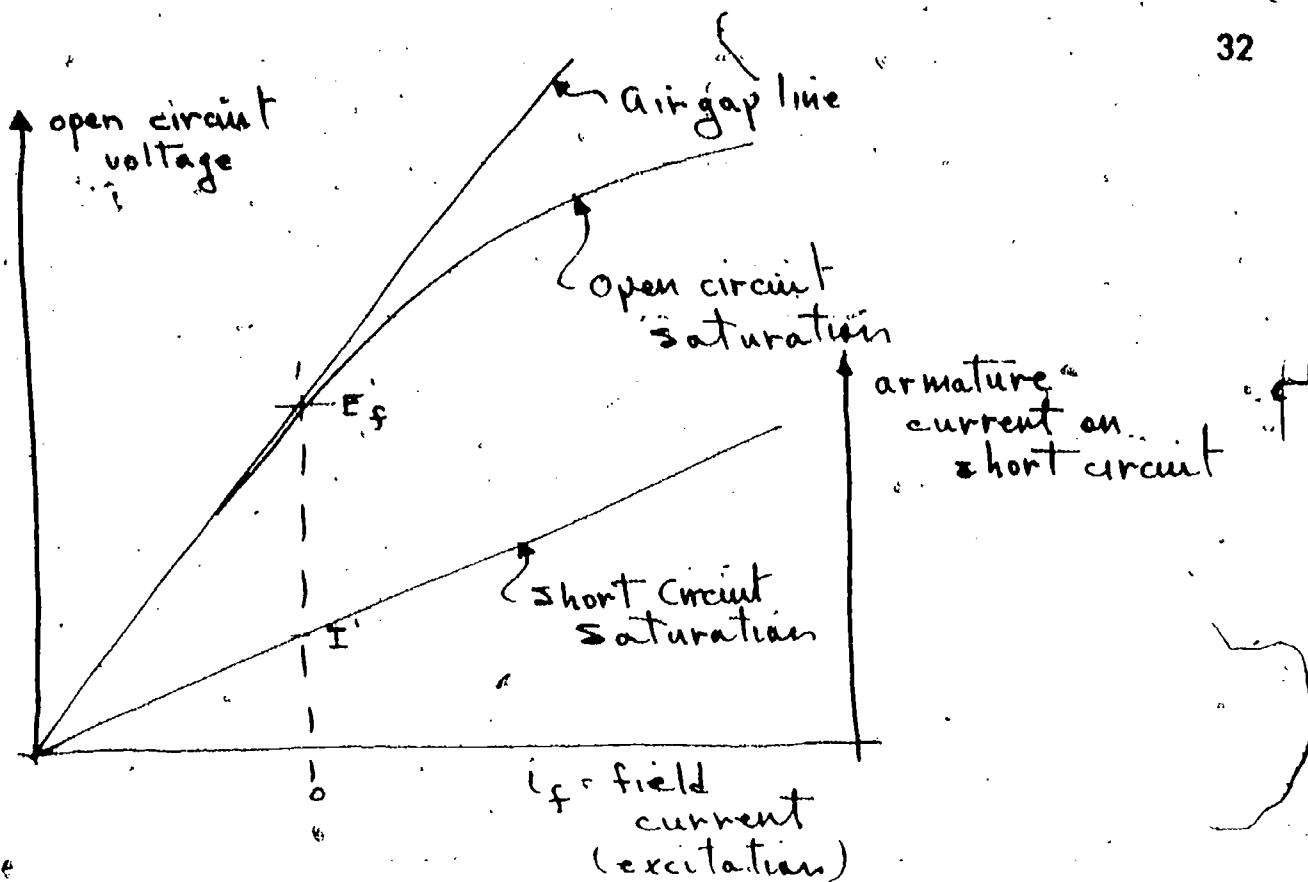

The short circuit saturation curve is obtained by driving the machine being tested at rated speed with the armature short circuited and recording armature and field current for field current values over the range from zero to 125-150% of rated value. Note that readings are taken for short circuit currents in the steady state, i.e., after any transients associated with the change in i_f have decayed out.

If $X_d \gg r$, I_a lags E_f by 90° and $I_a = I_d$. Also, on short circuit, $V_{ta} = 0$. Therefore

$$X_d = \frac{E_f}{I_d} = \frac{\omega L_{df}}{\sqrt{2}} \frac{I_f}{I_d}$$

and

$$L_d = \frac{L_{df}}{\sqrt{2}} \frac{I_f}{I_d}$$

Since the open circuit saturation curve is E_f for a specific i_f , and the short circuit saturation curve is I_a for a specific excitation, the ratio

$$\frac{E_f}{I'} = X_d$$

in the typical curves. The values shown would represent an unsaturated value of X_d because the level of excitation is below the "knee" of the saturation characteristic.

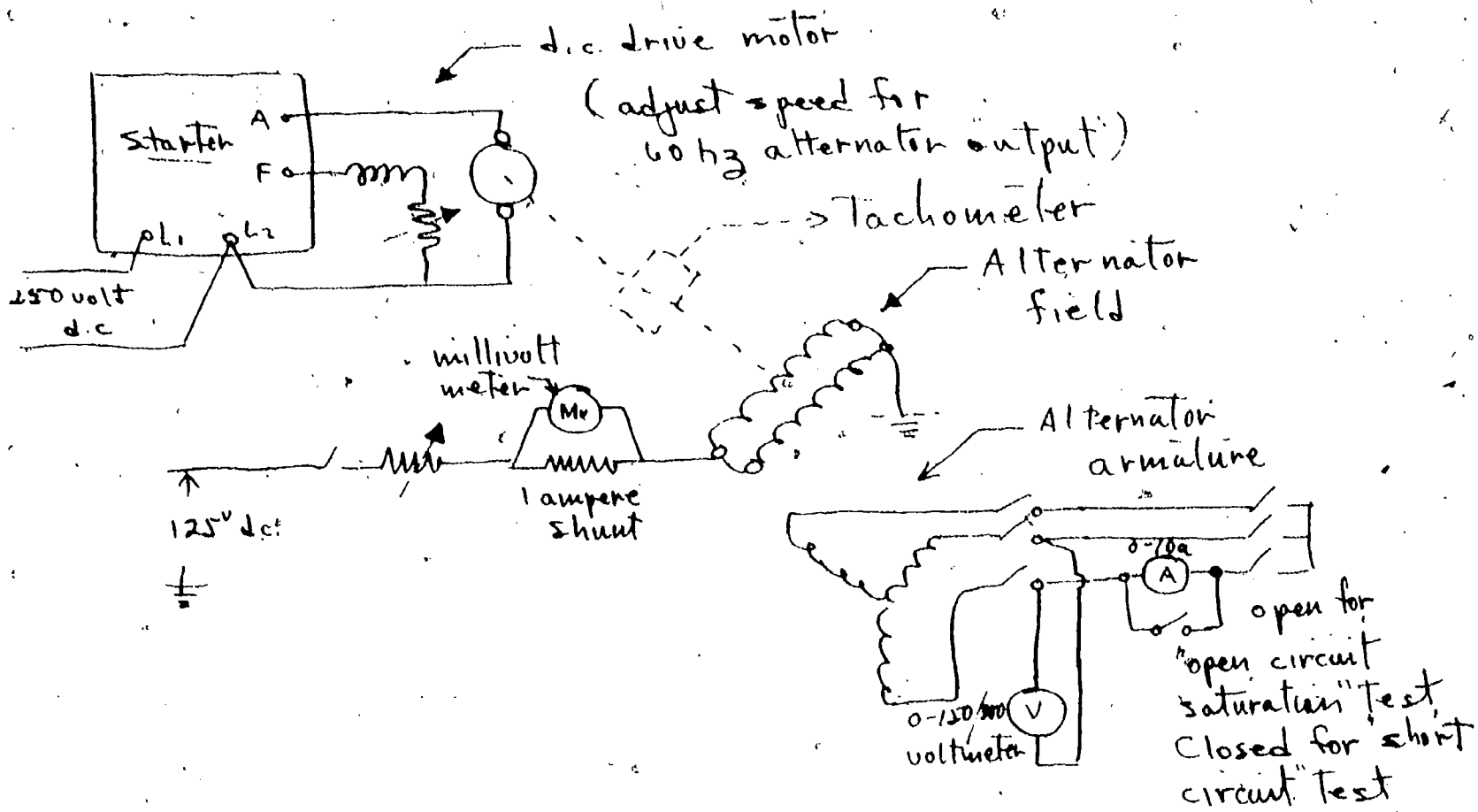

Note - reduce field current of the alternator to its minimum value, and short around the ammeter before short circuiting the alternator

Lab Connection for Open Circuit Saturation Test and Short Circuit Saturation Test.

wiring Diagram 8-1.

Section 3.05.35 and 3.05.50 in IEEE #115 gives details on conducting the tests. Section 7.15.10 discusses the determination of L_d from these characteristics.

Section 7.20.05, .10, .15 and .20 give details on the test procedure for obtaining L_q . The most common method of determining L_q is use of the "slip test". In this test, the machine is driven mechanically at a speed slightly different from synchronous speed with its field winding open and with balanced polyphase voltages of the correct phase sequence (same direction of rotation of the armature as for the field) applied to the armature.

In order to reduce reluctance torques and permit very small slips, the applied voltage should be a fraction of the rated voltage. Wiring Diagram 8-2 shows the connection diagram to be used for this test.

Because of the slip between the revolving armature field and the excitation field, the armature mmf wave glides slowly past the field poles (at slip speed). When the armature mmf wave is in line with the axis of the field poles the impedance of the machine is the d axis impedance and is a maximum. One quarter of a cycle later, the axis are in quadrature and the impedance equals the q axis impedance and is a minimum. If recordings, or oscillographs, of armature current and terminal voltage are obtained, the ratio of X_q/X_d is obtained. L_q can then be determined from:

$$L_q = L_d \left(\frac{X_q}{X_d} \right)$$

The values of the transient and subtransient inductances and time constants as required for transient response analysis can be determined from the short circuit currents recorded as a function of time. References in IEEE #115 for these quantities are:

X'_d	7.25
X''_d	7.30
X''_q	7.35
T'_{do}	7.65
T'_d	7.70
T''_{do}	7.75
T''_d	7.80
T_a	7.85

The laboratory instructor will demonstrate sudden short circuit tests and recordings of armature current as a function of time will be made available.

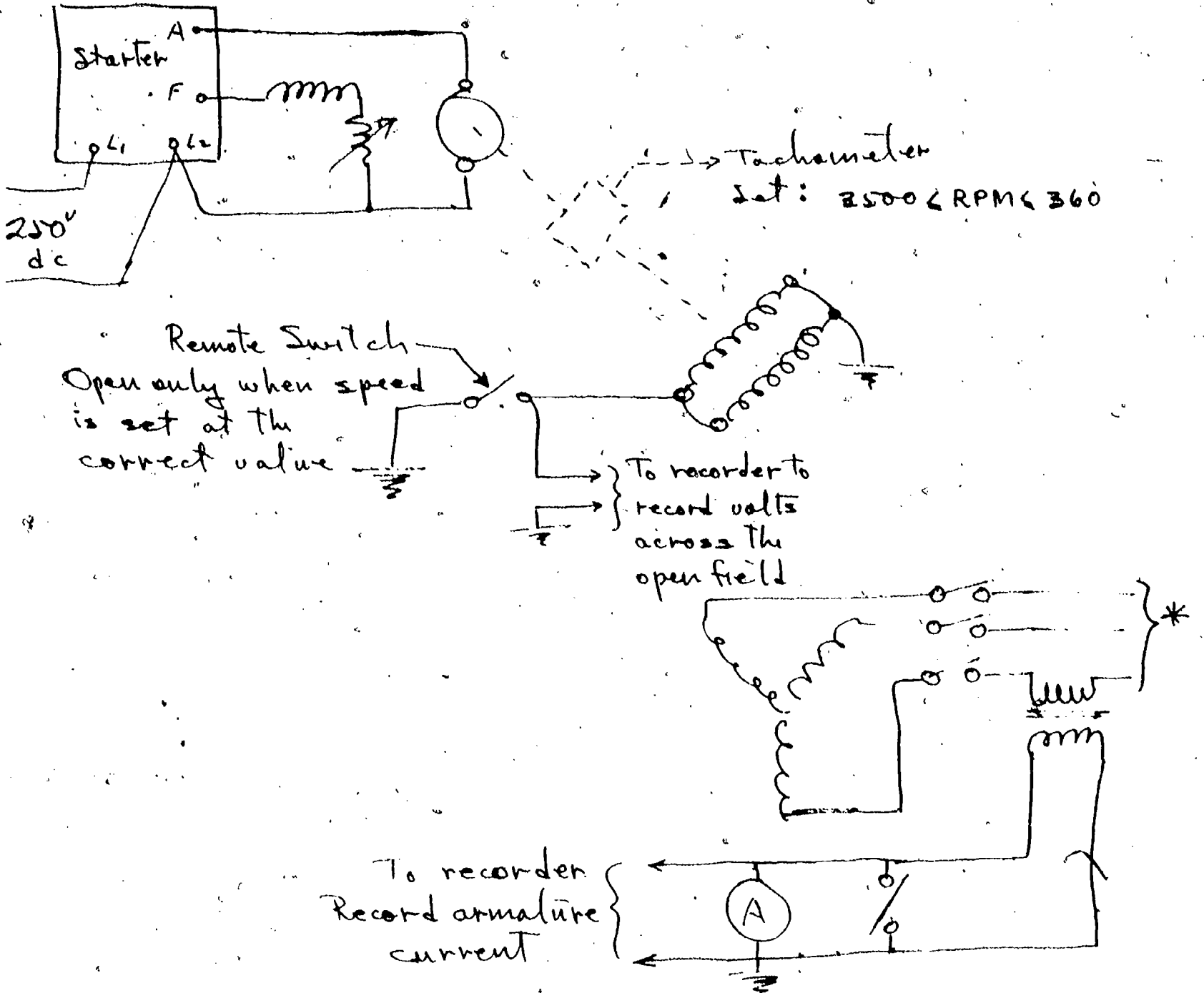

Lab Connection for Determining X_g by the "Slip Test"



In this lab period, obtain data necessary to determine r , L_d , L_q and L_{df} .

In the lab report, calculate the parameters required for steady state analysis and from the sudden short circuit recordings furnished by the instructor, calculate X_d'' and X_d' .

SYNCHRONOUS MACHINES

Experiment 9

Synchronous Alternator and Motor Characteristics

Voltage Regulation

Arrange to drive the synchronous machine as an alternator driven by a d.c. motor. Connected rated ohmic resistance load across the terminals and adjust the field excitation so as to obtain rated terminal voltage. Make certain the machine is driven at rated speed. Observe the voltage, current, and excitation. Switch the load off, bring the speed back to rated, and observe the terminal voltage. The observed voltage regulation can be calculated as

$$\% \text{ Volt. Reg.} = \frac{V_{\text{no load}} - V_{\text{full load}}}{V_{\text{full load}}}$$

Compare this value with the value you calculate using machine parameters measured in Experiment 8.

Synchronous Motor Excitation Characteristics

Connect the machine to run as a synchronous motor driving a d.c. generator. The scheme will be to maintain constant power load on the shaft of the synchronous motor while the excitation on the motor is varied from minimum (and still maintain synchronism) to maximum value (all external resistance removed). Do this for at least two values of constant shaft power. Read and record d.c. generator power output, synchronous motor line current, field current, and terminal voltage. The data obtained can be plotted as "Vee" curves. These curves illustrate the very important characteristic of the synchronous motor whereby the motor appears to the source as being either inductive, resistive, or capacitive—depending upon field excitation and load.

Discuss this in your report.

ASYNCHRONOUS MACHINES

Experiment 10

Asynchronous Machines as Frequency Converters

This experiment is designed to demonstrate the relationship of the revolving rotor and stator fields in an asynchronous machine. Recall from the lecture theory that the rotor and stator fields must be stationary with respect to each other. Speed voltages are induced in the rotor of magnitude:

$$V_{\text{rotor}} = \sigma V_{\text{stator}} \quad (9-1)$$

and of frequency

$$f_{\text{rotor}} = \sigma f_{\text{stator}} \quad (9-2)$$

where

$$\sigma = \text{slip} = \frac{\omega_{\text{stator}} - \omega_{\text{mech}}}{\omega_{\text{stator}}} \quad (9-3)$$

and

$$\omega = \text{angular velocity}$$

with the subscript notation denoting rotor, stator or mechanical speed.

From (9-3):

$$\sigma \omega_{\text{stator}} + \omega_{\text{mech}} = \omega_{\text{stator}} \quad (9-4)$$

Now:

$$\sigma \omega_{\text{stator}} = \frac{4\pi\sigma f}{p} = \frac{4\pi f_{\text{rotor}}}{p} \quad (9-5)$$

From (9-5):

$$\sigma \omega_{\text{stator}} = \omega_{\text{rotor}} \quad (9-6)$$

Therefore, from (9-6) and (9-4)

$$\omega_{\text{rotor}} + \omega_{\text{mech}} = \omega_{\text{stator}} \quad (9-7)$$

Since ω_{rotor} is the speed of the rotor field with respect to the rotor, the net speed of the rotor field with respect to a stationary reference, i.e., the stator, is ω_{stator} , the fields are stationary with respect to one another.

If we energize the stator from a constant frequency source, the stator field revolves at constant angular velocity. If we drive the rotor at various mechanical speeds we can verify the relationship in (9-7) by checking the frequency of the voltage induced in the rotor. In order to prevent the induction, or asynchronous machine, from developing a torque and to permit driving it at some desired speed, we must leave the rotor open circuited. Actually, this configuration has been used commercially as a frequency changer!

The connection diagram for investigating the rotor voltage-frequency relationships is shown in Figure 9-1. The d.c. drive motor should be varied from as near zero as possible to maximum safe speed in each direction of rotation or the direction of rotation of the induction machine stator can be reversed by interchanging two phase leads. The idea is to vary slip σ over the range 0.2 to 2⁺ and observe the rotor voltage and frequency. Frequency is measured by means of the Lissajous figure on a cathode ray oscilloscope. Rotor voltage can be measured by a voltmeter with appropriate frequency response.

In your report, discuss the phenomena observed and display graphically.

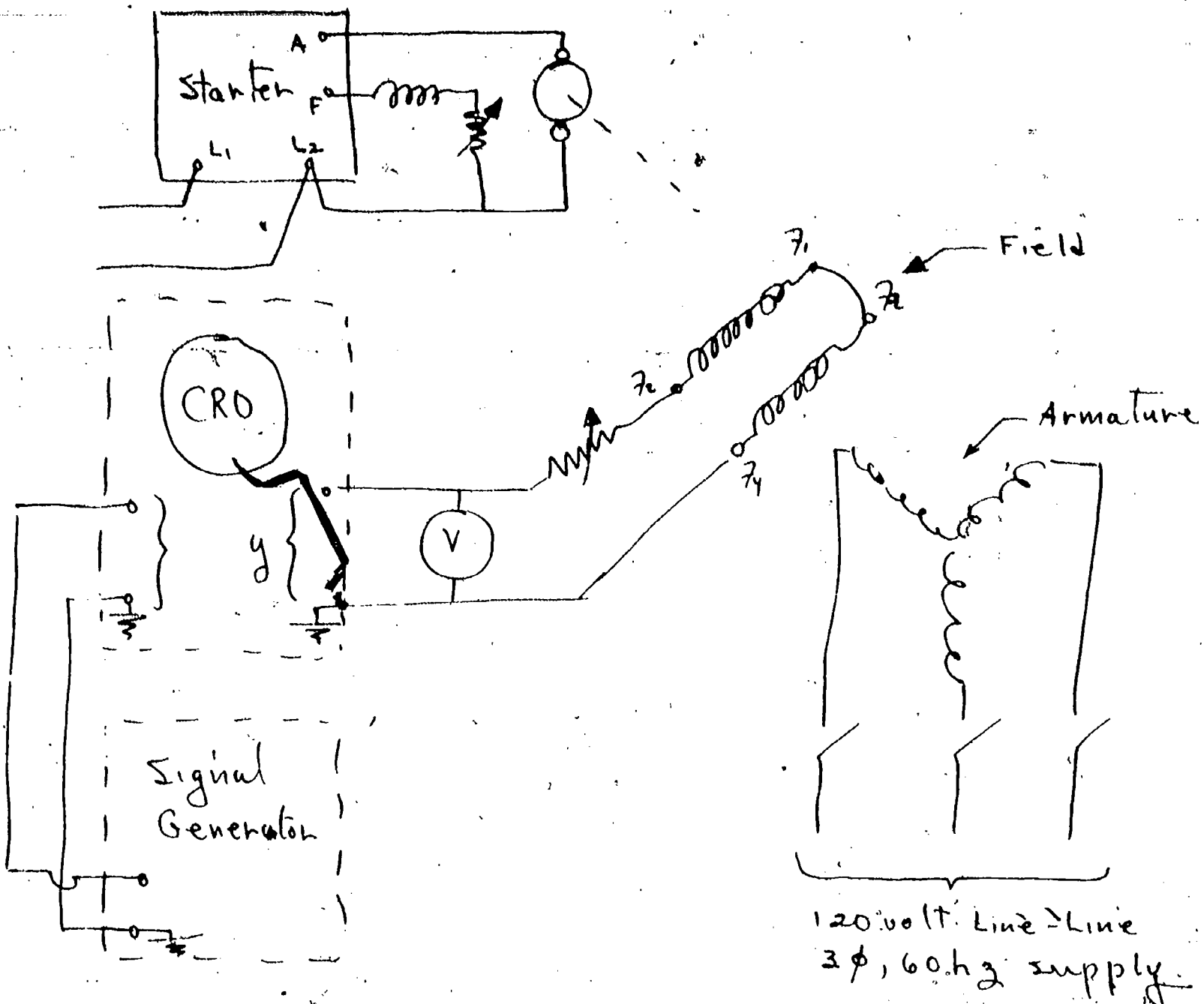

Lab Connections for Frequency Changer Operation

Wiring Diagram 9-1

Experiment 11

The Speed-Torque Curve of an Induction Motor

In the lecture, the approximation to the speed-torque relationships of the induction motor is derived as:

$$T = \frac{2 T_m}{\frac{\sigma_m}{\sigma} + \frac{\sigma}{\sigma_m}}$$

where

T_m = maximum, or "breakdown", torque

σ_m = slip at which T_m occurs

T = torque at any slip, σ .

This approximation is based on the assumption that stator resistance can be neglected in the steady state behavior.

In this lab exercise, connect the Westinghouse universal machine as an induction motor (refer to the schematic of the machine). Energize the machine from the 120 V_{LL}, 60 cps, 3 phase source and record speed and torque after obtaining suitable calibration of the transducers. From the data obtained, calculate the constants in the approximation above and plot the approximation on the same sheet as the actual observed characteristic is plotted in order to evaluate the validity of the approximation for this machine.